



HYDRAULIC EXCAVATOR | JS130LC/JS130LC Dozer

Engine power: 74kW (100hp) Bucket capacity: 0.34 – 0.85m³ Operating weight: 13,661 – 14,408kg



STRENGTH INSIDE AND OUT.

BEFORE YOU BUY AN EXCAVATOR, YOU NEED TO KNOW IT'S GOING TO BE TOUGH ENOUGH TO PERFORM ANY JOB YOU ASK OF IT. FORTUNATELY, WITH A JCB JS115/130/145, STRENGTH AND DURABILITY COME AS STANDARD.



1

Boom and dipper.

1 A JCB JS130LC's reinforced boom and dipper is made of high tensile strength steel, with single piece wrapper plates and internal baffle plates for long life durability.

2 Our advanced manufacturing and assembly processes produce high precision and quality assembled components.



2

Componentry.

3 Our engine technology is tried and proven; we've built 200,000 DIESELMAX units since 2004. To ensure similar longevity, the JS130LC's DIESELMAX engine has been tested for 110,000 hours in 70 different machines across the toughest applications and environments.

4 JCB JS130LC's boast the best components in the industry, including Berco running gear, Kawasaki pumps, Kayaba valve blocks and JCB DIESELMAX engines.

We use Finite Element Analysis with extensive rig and endurance testing to make key components last longer.



3



4



Structural strength.

- 5 The high-strength undercarriage of a JCB JS130LC uses a fully-welded X frame construction for long-term durability even in the most demanding applications.
- 6 A closed box section revolving frame increases strength and reduces stress. It's also highly resistant to impact damage.
- 7 The JS130LC high-strength rigid upper frame provides maximum durability and support.
- 8 Our stiff, durable door design gives great strength and rigidity.

UNEARTHED: KEY FACT

The JCB JS130LC turret is welded to both the upper and lower undercarriage frame.



5



6



8



7

MAXIMUM PRODUCTIVITY, MINIMUM SPEND.

SAVING MONEY AND TIME IS MORE IMPORTANT THAN EVER, SO WE'VE MADE SURE THE NEW JCB JSI30LC'S COMPONENTRY – INCLUDING THE DIESELMAX T3 ENGINE – WORKS IN PERFECT HARMONY. IN TURN, YOU GET A MACHINE THAT'S AS EFFICIENT AND PRODUCTIVE AS POSSIBLE.

Versed in versatility.

1 JCB's quickhitch system makes attachment changing fast and easy, and is purpose-designed for the JS range.

JCB offers a full list of auxiliary pipework options including hammer, auxiliary, and low flow. For ultra versatility these auxiliary options are available with proportional controls.

2 An optional dozer blade increases versatility for grading. Choose the optional rubber street pads and you can use the JSI30LC on sensitive grounds like tarmac without causing damage.

3 The JSI30LC's relatively low operating weight means it can be towed on a lorry*, making it portable for plant hire and inner city/urban applications.

4 For waterway maintenance and deep extraction, or any application where reach is paramount, the JS145 is available with a long reach boom and arm. See our long reach brochure for further details.

* Territory dependant.



The JSI30LC is a hugely versatile machine, made all the more so by a big range of attachments, enabling you to carry out a wide range of tasks.



Upping output.

- 6 Simultaneous tracking and excavating is smooth and fast with an intuitive multifunction operation.
- 6 A JCB JS130LC has a solid, stable work platform for fast cycle times.
- 7 With a massive 92kN bucket tearout and fast cycle times, the JS130LC is extremely productive in all applications.
- 6 JCB's innovative hydraulic regeneration system means oil is recycled across the cylinders for faster cycle times and reduced fuel consumption.

The efficient excavator.

- 9 To reduce noise pollution from unnecessary air flow, the JS130LC's engine-driven cooling fan has a proportional control system, maintaining optimum fan speed.
- 10 Variable power bands allow you to tailor performance – and therefore economy – to specific tasks.



To save fuel, JCB Auto-Idle technology automatically reduces engine speed when hydraulics aren't in use. To optimise fuel efficiency still further, the JS130LC benefits from advanced hydraulic technology, including optimised hydraulic pump settings, advanced spool design, and cutting edge electronic management software.

UNEARTHED: KEY FACT
A JCB JS130LC has cushioned boom and dipper ends to prevent shock loadings, protect your machine and increase operator comfort.



A COMFORTABLE FAVOURITE.

JCB EXCAVATORS ARE DESIGNED AROUND THE OPERATOR. THAT'S GOOD FOR THEM BUT EVEN BETTER FOR YOU; AFTER ALL, GREAT COMFORT AND EASE OF USE EQUALS GREAT PRODUCTIVITY.

Visibly better.

1 A 70/30 front screen split gives JCB JS130LCs excellent front visibility. A clear view of the front right track provides easy, safe trench digging and manoeuvring.

2 An innovative low-level bonnet provides excellent rearward visibility.

Comfortably in control.

3 The 3.5" colour multi-function display is easy to read in all light conditions, provides instant operational information, and has a customisable home screen.



A large laminated glass roof window gives the JS130LC optimum visibility for working at height.

Light, intuitive and smooth controls improve comfort and productivity. The JS130LC's joystick-mounted power boost button gives extra hydraulic power fast.

A balanced slew and electronic/hydraulic controlled slew braking give speed and precision.



The JS130LC's cab and controls are independently adjustable so that it's easy to find the perfect operating position.

The working environment.

4 The JS130LC creates a quieter working environment inside and out. Because we've reduced noise levels to 72dB(A) inside and 99dB(A) outside, you can use the machine at any location, any time.

JCB cabs use 6 viscous rubber mounts to minimise noise and vibration.

The positive pressure cab keeps out dirt and dust.

5 JCB's climate control option offers a precisely controlled cab temperature with fresh or recirculated air. Demisting/defrosting functions keep a JS130LC's front window clear.

6 There's a spacious luggage tray behind the operator's seat.

7 A large floor area with large high grip pedals gives easy and precise tracking.



5



6



7



4

We offer air suspension, heated and ventilated seating options to suit many different applications.

LESS SERVICING, MORE SERVICE.

WE'VE DESIGNED THE JCB JSI30LC TO BE LOW MAINTENANCE AND EASILY SERVICEABLE. THIS MAKES IT AFFORDABLE, EFFICIENT AND HIGHLY PRODUCTIVE, HELPING YOU GET THE BEST SERVICE FROM YOUR MACHINE.



1



(A) Hydraulics oil filters (B) Fuel filters

Easy does it.

- 1 The air filter on a JSI30LC is easily accessible, and a double-element construction simplifies cleaning.
- 2 The filters on a JSI30LC (engine oil, hydraulic oil and fuel) are centrally located for fast, easy servicing.
- 3 Because they're mounted side by side on a JCB JSI30LC, the engine radiator, hydraulic cooler and intercooler can be serviced individually yet cleaned easily.

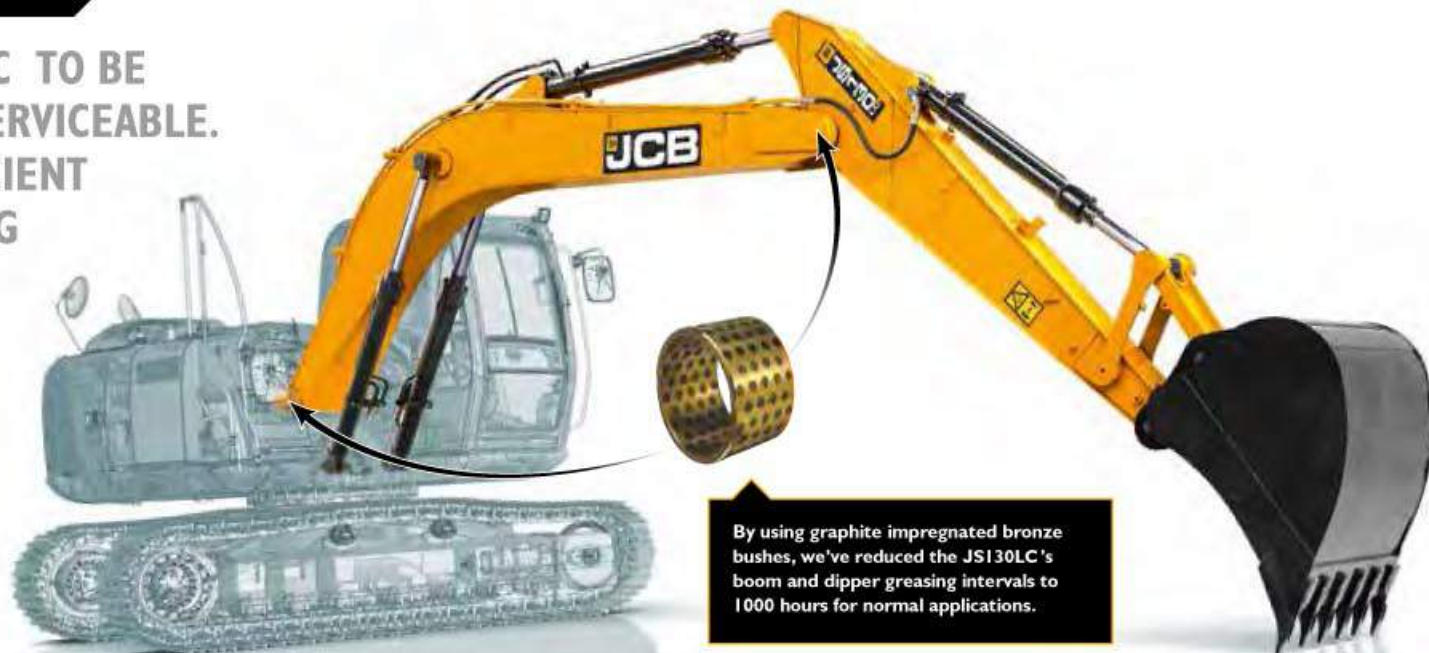

By using graphite impregnated bronze bushes, we've reduced the JSI30LC's boom and dipper greasing intervals to 1000 hours for normal applications.

SERVICE INTERVALS	
Engine oil and oil filter	Every 500 hours
Hydraulic oil	Every 5000 hours
Hydraulic oil filter	Every 1000 hours



3

Here to help.

- 4 Service your JCB with your local main dealer and our trained engineers can minimise downtime.
- 5 Order genuine JCB parts online and, in 95% of cases, they'll be with you next day. For extra security and machine protection, opt for a package like JCB LiveLink remote machine monitoring.
- 6 We've eliminated the need for a visibowl style pre-cleaner on the JS130LC with our new optional scavenger filtration system. This uses suction from the cooling fan to remove heavier particles from the induction system.
- 7 JCB's In-Cab Monitor checks engine oil levels, coolant, and system errors on start-up.



UNEARTHED: KEY FACT
 JCB JS130LC grease points are centralised for safe and easy access to high level pivots.

JCB JS130LC bonnets open and close easily with gas-assisted cylinders, and the service bays are large and wide for good access.



THE SAFE CHOICE.

ON-SITE SAFETY IS CRUCIAL, SO WE'VE DESIGNED THE JCB JSI30LC TO INCORPORATE AS MANY CUTTING EDGE SAFEGUARDS AS POSSIBLE. IN SHORT, YOUR OPERATORS ARE IN SAFE HANDS.



1 The JSI30LC bonnet opens front-to-rear for easy and safe engine service access.



2 For extra peace of mind, JCB cabs are available with an integral Rollover Protection Structure (ROPS). It's also easy to fit JCB's Falling Objects Protection Structure (FOPS), thanks to standard fitment mounting brackets.

3 JCB JSI 30LCs have a large glass area and low bonnet line for superb visibility.

4 A JCB JSI 30LC's steps and platforms have anti-slip punched steel plates for optimum grip, even in wet or icy conditions. Bolt-on plates have recessed bolts to reduce trip hazards.

5 Our optional rear and side view cameras display uninterrupted rearwards and sideways views on the smart controller display.



We've fitted as standard a bulk head heat shield between the pumps and the engine to guard against heat and noise.



6 Your JSI 30LC is equipped with a full set of side and rear view mirrors for all round visibility and safety compliance.

7 JCB's Safety Level Lock fully isolates hydraulic functions to avoid unintended movements. Our 2GO system means a JCB JSI 30LC can only be started in a safe locked position via two separate inputs.

8 There's no need to climb onto the JSI 30LC to check oil levels; all routine servicing can be done from ground level.

9 Optional safety rails protect operators from falls when they're on the upper structure of the JSI 30LC.

10 The JSI 30LC's optional beacons can improve on-site safety still further.

11 Choose LED work lights for an even better field of vision on the JSI 30LC.



12



7



8



9



11

LIVELINK, WORK SMARTER.

LIVELINK IS AN INNOVATIVE SOFTWARE SYSTEM THAT LETS YOU MANAGE JCB MACHINES REMOTELY – ONLINE, BY EMAIL OR BY MOBILE PHONE. ACCESS EVERYTHING FROM MACHINE ALERTS TO FUEL REPORTS AND HISTORY INFORMATION, WITH ALL DATA STORED AT A SECURE CENTRE.

Productivity and cost benefits

By providing information like idle time monitoring and machine fuel consumption, JCB Livelink helps reduce your fuel usage, saving money and improving productivity. Machine location information can help improve efficiency and perhaps even reduce insurance costs.



Maintenance benefits

Manage machine maintenance easily – accurate hours monitoring and service alerts improve maintenance planning, while real-time location data helps you manage your fleet. Critical machine alerts and maintenance history records are also available.



Security benefits

Livelink's real-time geofencing alerts tell you when machines move out of predetermined zones, and real-time curfew alerts inform you of unauthorised usage. Further benefits include real-time location information, advanced ECU matching (pairs Livelink with the immobiliser or ECU).



VALUE ADDED.

JCB'S WORLDWIDE CUSTOMER SUPPORT IS FIRST CLASS. WHATEVER YOU NEED AND WHEREVER YOU ARE, WE'LL BE AVAILABLE QUICKLY AND EFFICIENTLY TO HELP MAKE SURE YOUR MACHINERY IS PERFORMING TO ITS FULL POTENTIAL.



1 Our Technical Support Service provides instant access to factory expertise, day or night, while our Finance and Insurance teams are always on hand to provide fast, flexible, competitive quotes.

E The global network of JCB Parts Centres is another model of efficiency; with 15 regional bases, we can deliver around 95% of all parts anywhere in the world within 24 hours. Our genuine JCB parts are designed to work in perfect harmony with your machine for optimum performance and productivity.

Note: JCB LIVELINK and JCB ASSETCARE may not be available in your region, so please check with your local dealer.



3 JCB Assetcare offers comprehensive extended warranties and service agreements, as well as service-only or repair and maintenance contracts. Irrespective of what you opt for, our maintenance teams around the world charge competitive labour rates, and offer non-obligation quotations as well as fast, efficient insurance repair work.

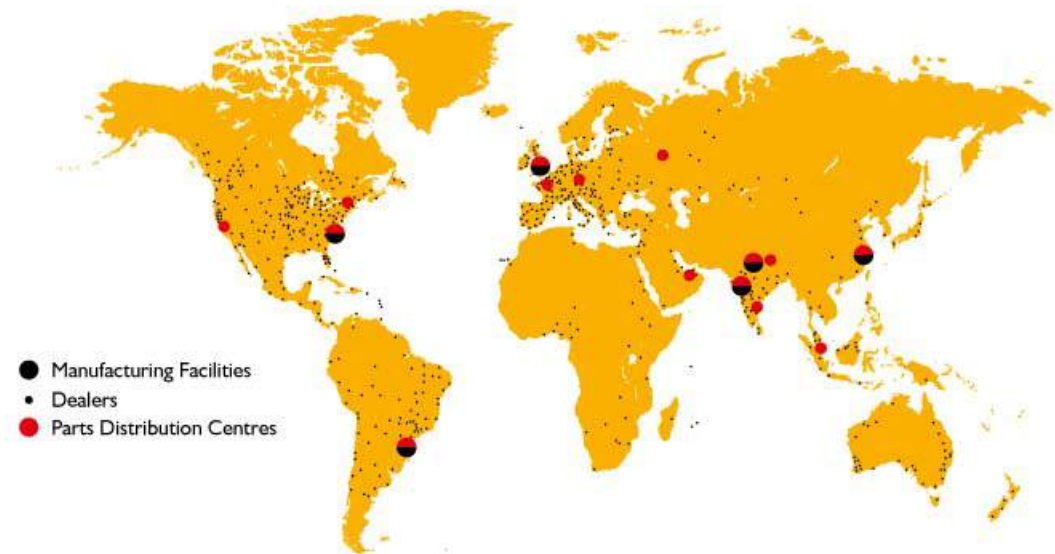

STATIC DIMENSIONS

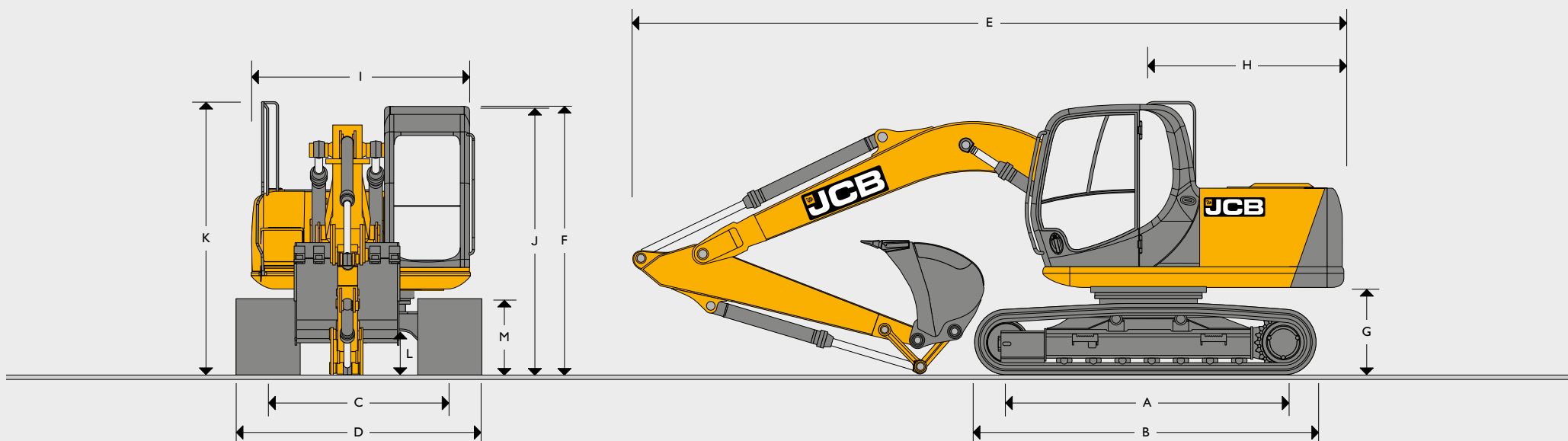

Dimensions in mm	JSI30 MONO			
A Track length on ground	2865			
B Undercarriage overall length	3605			
C Track Gauge	1990			
D Width over tracks (500mm trackshoes)	2490			
D Width over tracks (600mm trackshoes)	2590			
D Width over tracks (700mm trackshoes)	2690			
D Width over tracks (800mm trackshoes)	-			
D Width over tracks (850mm trackshoes)	2840			
D Width over tracks (900mm trackshoes)	-			
Arm lengths	2.1m	2.5m	2.7m	3.0m
E Transport length	7515	7478	7420	7300
F Transport height	2867	2867	3209	3289
G Counterweight clearance*	905			
H Tail swing radius	2135			
I Width of superstructure	2410			
J Height over cab*	2845			
K Height over grab rail*	2867			
L Ground clearance*	425			
M Track height	811			

*Height with upperstructure safety rails: 2967mm.

ENGINE	
Model	JCB DIESELMAX 444 TCA 74, Stage IIIA, Tier 3 emissions compliant.
Type	Water cooled, 4-stroke, 4-cylinder in-line, common rail injection, turbocharged variable geometry intercooled diesel.
Rated power (ISO 14396)	74kW (100hp) at 2200rpm.
Piston Displacement	4.399 litres.
Injection	Electronic governor.
Air Filtration	Dry.
Cooling	Large capacity radiator.
Starting system	24 volt - 4kW.
Batteries	2 x 12 volt.
Alternator	24 volt 55 amp.
Refuelling pump	Electric type (optional).

SWING SYSTEM	
Swing motor	Axial piston type
Swing brake	Hydraulic braking plus automatic spring applied disc type parking brake.
Swing speed	JS130LC 13.3 rpm
Swing gear	Large diameter, internally toothed fully sealed grease bath lubricated.
Swing lock	Multi position switchable brake

UNDERCARRIAGE	
Recovery point	Front and rear.
Upper & lower rollers	Heat treated, sealed and lubricated.
Track adjustment	Grease cylinder type.
Track type	Sealed and lubricated.
Track idler	Sealed and lubricated, with spring cushioned recoil.
Track shoes	JS130LC
	500mm triple grouser 500mm GEOGRIP
	600mm triple grouser 500mm Rubber shoes
	700mm triple grouser 600mm Rubber shoes
	850mm triple grouser
Rollers and Shoes (each side)	JS130LC
Upper rollers	2
Lower rollers	7
Track shoes	44

TRACK DRIVE	
Type	Fully hydrostatic, three speed with autoshift between high and medium speed.
Travel motors	Variable swash axial piston type, fully guarded within undercarriage frame.
Final drive	Planetary reduction, bolt-on sprockets.
Servic brake	Hydraulic counter balance valve to prevent overspeeding on gradients.
Park brake	Disc type, spring applied, automatic hydraulic release.
Gradeability	70% (35 deg) continuous.
Travel speed	JS130LC
	High - 6.6 km/h
	Mid - 3.8 km/h
	Low - 2.3 km/h
Tractive effort	87.5kN

HYDRAULIC SYSTEM	
Pumps	
Main pumps	2 variable displacement axial piston type.
Maximum flow	2 x 124 L/min.
Servo pump	Gear type.
Maximum flow	20 L/min.
Control valve	
A combined four and five spool control valve with auxiliary service spool as standard	
Relief valve settings	
Boom/Arm/Bucket	314 bar.
With power boost	343 bar.
Swing circuit	279 bar.
Travel circuit	343 bar.
Pilot control	40 bar.
Filtration	
In tank	150 micron, suction strainer.
Main return line	10 micron, glass fibre element.
Pilot line	10 micron, paper element.
Hydraulic hammer return	10 micron, reinforced microform element.

SERVICE CAPACITIES	
	Litres
Fuel tank	220
Engine coolant	19.7
Engine oil	14
Swing reduction gear	2.2
Track reduction gear (each side)	3.5
Hydraulic system	126
Hydraulic tank	73

WEIGHTS AND GROUND BEARING PRESSURES

Shoe Width	Operating Weight	Bearing Pressure
JS130LC - Machine equipped with 4.7m Monoboomb, 2.5m Dipper, 417kg Excavating Bucket, operator and full fuel tank.		
500mm	13661kg	0.44kg/sq.cm
600mm	13768kg	0.37kg/sq.cm
700mm	13876kg	0.32kg/sq.cm
850mm	14038kg	0.27kg/sq.cm

BUCKET AND ARM COMBINATION

JS130LC	No Q/Hitch Fitted				Q/Hitch Fitted*				Bucket weight
	2.1m	2.5m	2.7m	3.0m	2.1m	2.5m	2.7m	3.0m	
Arm length									
GP bucket 610mm. 0.34m ³	□	□	□	□	□	□	□	□	368kg
GP bucket 762mm. 0.46m ³	□	□	□	□	□	■	■	●	460kg
GP bucket 914mm. 0.59m ³	□	□	■	●	●	●	✘	✘	511kg
GP bucket 1067mm. 0.72m ³	□	■	■	✘	●	✘	✘	✘	579kg
GP bucket 1219mm. 0.85m ³	■	■	●	✘	✘	✘	✘	✘	625kg

□ = Suitable for general excavating (materials up to 2000kg/cu.m).

■ = Suitable for light excavating (materials up to 1600kg/cu.m.)

● = Suitable for grading & loading materials up to 1200kg/cu.m).

✘ = Not recommended

* Bucket capacity using JCB quickhitch only (quickhitch = 186kg).

WORKING RANGE			JSI30LC
Boom length:			4.70m
Dipper length:			2.10m
A	Maximum digging reach	mm	7517
B	Maximum digging reach (on ground)	mm	7356
C	Maximum digging depth	mm	4809
D	Maximum digging height	mm	8375
E	Maximum dumping height	mm	6115
F	Maximum vertical wall cut depth	mm	3219
G	Minimum swing radius	mm	2337
Bucket rotation			182°
Maximum dipper tearout (ISO 6015)		kgf	7394
Maximum bucket tearout (ISO 6015)		kgf	9375
Dipper length:			2.50m
A	Maximum digging reach	mm	8340
B	Maximum digging reach (on ground)	mm	8197
C	Maximum digging depth	mm	5530
D	Maximum digging height	mm	9118
E	Maximum dumping height	mm	6729
F	Maximum vertical wall cut depth	mm	3625
G	Minimum swing radius	mm	2231
Bucket rotation			182°
Maximum dipper tearout (ISO 6015)		kgf	6589
Maximum bucket tearout (ISO 6015)		kgf	9375
Dipper length:			2.70m
A	Maximum digging reach	mm	8522
B	Maximum digging reach (on ground)	mm	8380
C	Maximum digging depth	mm	5425
D	Maximum digging height	mm	9242
E	Maximum dumping height	mm	6855
F	Maximum vertical wall cut depth	mm	4444
G	Minimum swing radius	mm	2505
Bucket rotation			182°
Maximum dipper tearout (ISO 6015)		kgf	6447
Maximum bucket tearout (ISO 6015)		kgf	9375
Dipper length:			3.00m
A	Maximum digging reach	mm	8796
B	Maximum digging reach (on ground)	mm	8660
C	Maximum digging depth	mm	6028
D	Maximum digging height	mm	9440
E	Maximum dumping height	mm	7041
F	Maximum vertical wall cut depth	mm	4050
G	Minimum swing radius	mm	2591
Bucket rotation			182°
Maximum dipper tearout (ISO 6015)		kgf	5988
Maximum bucket tearout (ISO 6015)		kgf	9375

OPTIONAL BLADE

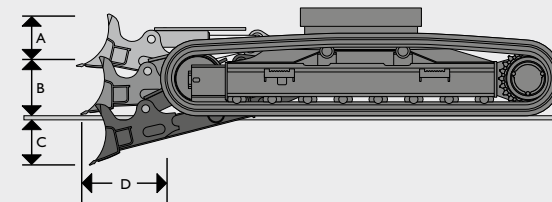

			JSI30LC
A	Blade height	mm	490
B	Blade lift above ground	mm	440
C	Blade cut below ground	mm	510
D	Blade forward of track	mm	440
Dozer width – 500mm tracks		mm	2510
Dozer width – 600mm tracks		mm	2610
Dozer width – 700mm tracks		mm	2710
Additional machine weight with blade			
500mm tracks		kg	747
600mm tracks		kg	753
700mm tracks		kg	759

WORKING RANGE

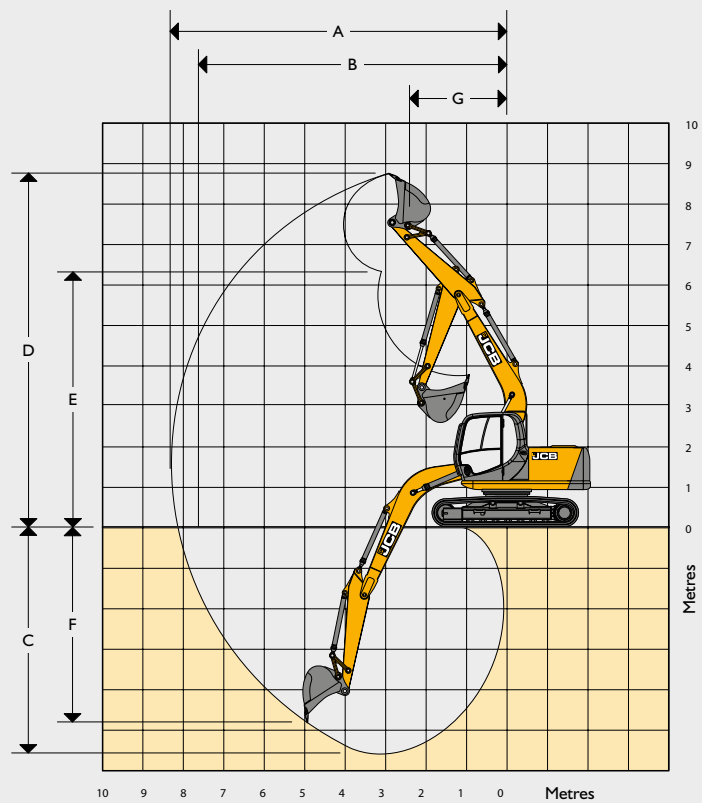

JSI30LC

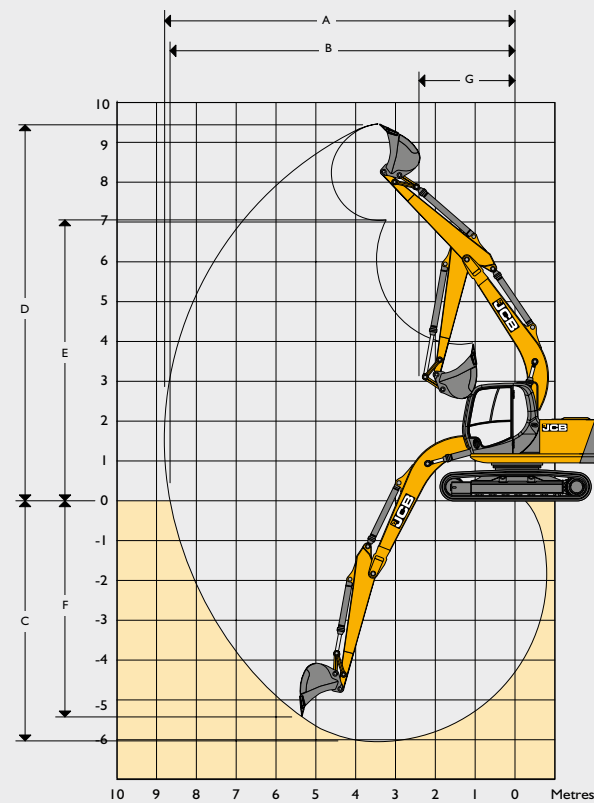

JSI30LC MONOBOOM

LIFT CAPACITIES – DIPPER LENGTH: 2.50M, 4.70M MONOBOOM, TRACKSHOES: 500MM, NO BUCKET. JS130 LC MONO

Reach	3m		4m		5m		6m		Capacity at Max Reach		mm
											
Load Point Ht.	kg	kg	kg	kg	kg	kg	kg	kg	kg	kg	mm
6.0m			2800*	2800*	3010*	3010*			2370*	2370*	5533
5.0m			2980*	2980*	3020*	3020*	3110*	2430	2240*	2240*	6221
4.0m	3860*	3860*	3490*	3490*	3270*	3210	3170*	2410	2190	2010	6689
3.0m	5400*	5400*	4250*	4250*	3680*	3110	3350	2360	2190*	1850	6982
2.0m	7130*	6310	5100*	4120	4150*	2990	2380	2290	2250*	1770	7121
1.0m	6370*	5990	5810*	3940	4200	2880	3210	2580	2360	1740	7116
0m	6830*	5860	5780	3820	4120	2810	3160	2180	2540*	1780	6967
- 1.0m	8630*	5820	5720	3770	4070	2760	3130	2160	2710	1880	6663
- 2.0m	8240*	5850	5720	3770	4060	2760	4140	2170	3020	2090	6181
- 3.0m	7460*	5930	5370*	3810	4100	2790			3620	2490	5474



Lift capacity front and rear.



Lift capacity full circle.





Notes:

1. For lifting capacity including bucket, subtract total weight of bucket or bucket and quickhitch from above values.
2. Lifting capacities are based on ISO 10567, that is: 75% of minimum tipping load or 87% of hydraulic lift capacity, whichever is the less. Lifting capacities marked* are based on hydraulic capacity.
3. Lift capacities assume that the machine is on firm, level ground.
4. Lift capacities may be limited by local regulations. Please refer to your dealer.

LIFT CAPACITIES – DIPPER LENGTH: 3.00M, 4.70M MONOBOOM, TRACKSHOES: 500MM, NO BUCKET. JS130 LC MONO

Reach	3m		4m		5m		6m		Capacity at Max Reach		mm
											
Load Point Ht.	kg	kg	kg	kg	kg	kg	kg	kg	kg	kg	mm
6.0m					2540*	2540*	2520*	2460	2180*	2180*	6113
5.0m					2610*	2610*	2720*	2470	2070*	2010*	6741
4.0m			2960*	2960*	2890*	2890*	2840*	2430	2030*	1790	7175
3.0m	4460*	4460*	3710*	3710*	3310*	3140	3080*	2370	2040*	1660	7448
2.0m	6210*	6210*	4600*	4180	3820*	3010	3280	2290	2090*	1590	7578
1.0m	7640*	6060	5410*	3960	4210	2880	3200	2220	2190*	1570	7574
0m	7510*	5830	5770	3810	4100	2780	3140	2160	2300	1590	7434
- 1.0m	8610*	5740	5670	3720	4030	2720	3090	2120	2420	1670	7150
- 2.0m	8430*	5730	5640	3690	4000	2700	3080	2100	2650	1820	6704
- 3.0m	7880*	5780	5660	3710	4020	2710	3110	2130	3070*	2110	6060

LIFT CAPACITIES – DIPPER LENGTH: 2.50M, 4.70M MONOBOOM, TRACKSHOES: 500MM, NO BUCKET, DOZER. JS130 LC MONO

Reach	3m		4m		5m		6m		Capacity at Max Reach		mm
											
Load Point Ht.	kg	kg	kg	kg	kg	kg	kg	kg	kg	kg	mm
6.0m			2800*	2800*	3010*	3010*			2370*	2370*	5533
5.0m			2980*	2980*	3020*	3020*	3110*	2540	2240*	2240*	6221
4.0m	3860*	3860*	3490*	3490*	3270*	3270*	3170*	2520	2190*	2110	6689
3.0m	5400*	5400*	4250*	4250*	3680*	3250	3370*	2470	2190*	1940	6982
2.0m	7130*	6600	5100*	4310	4150*	3130	3560	2410	2250*	1860	7121
1.0m	6370*	6280	5810*	4130	4570	3030	3500	2350	2360*	1840	7116
0m	6830*	6140	6260	4010	4480	2950	3440	2300	2540*	1870	6967
- 1.0m	8630*	6110	6240	3960	4440	2900	3420	2270	2840*	1980	6663
- 2.0m	8240*	6140	6240	3960	4430	2900	3420	2280	3290	2200	6181
- 3.0m	7460*	6210	5370*	4000	4460*	2940			3850*	2620	5474

LIFT CAPACITIES – DIPPER LENGTH: 3.00M, 4.70M MONOBOOM, TRACKSHOES: 500MM, NO BUCKET, DOZER. JS130 LC MONO

Reach	3m		4m		5m		6m		Capacity at Max Reach		mm
											
Load Point Ht.	kg	kg	kg	kg	kg	kg	kg	kg	kg	kg	mm
6.0m					2540*	2540*	2520*	2520*	2180*	2180*	6113
5.0m					2610*	2610*	2720*	2580	2070*	2070*	6741
4.0m			2960*	2960*	2890*	2890*	2840*	2540	2030	1880	7175
3.0m	4460*	4460*	3710*	3710*	3310*	3280	3080*	2480	2040*	1750	7448
2.0m	6210*	6210*	4600*	4370	3820*	3150	3380*	2410	2090*	1680	7578
1.0m	7640*	6350	5410*	4150	4310*	3020	3490	2330	2190*	1650	7574
0m	7510*	6120	5990*	4000	4470	2930	3420	2270	2350*	1680	7434
- 1.0m	8610*	6030	6200*	3910	4400	2860	3380	2230	2590*	1760	7150
- 2.0m	8430*	6020	6160	3880	4370	2840	3360	2220	2890	1920	6704
- 3.0m	7880*	6070	5970*	3900	4380	2850			3350	2220	6060

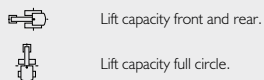

- Notes:
1. For lifting capacity including bucket, subtract total weight of bucket or bucket and quickhitch from above values.
 2. Lifting capacities are based on ISO 10567, that is: 75% of minimum tipping load or 87% of hydraulic lift capacity, whichever is the less. Lifting capacities marked* are based on hydraulic capacity.
 3. Lift capacities assume that the machine is on firm, level ground.
 4. Lift capacities may be limited by local regulations. Please refer to your dealer.



ONE COMPANY, OVER 300 MACHINES.

Your nearest JCB dealer

Hydraulic Excavator JSI 30LC

Engine power: 74kW (100hp) Bucket capacity: 0.34 – 0.85m³

Operating weight: 13,661 – 14,408kg

© 2009 JCB Sales. All rights reserved. No part of this publication may be reproduced, stored in a retrieval system, or transmitted in any form or by any other means, electronic, mechanical, photocopying or otherwise, without prior permission from JCB Sales. All references in this publication to operating weights, sizes, capacities and other performance measurements are provided for guidance only and may vary dependant upon the exact specification of machine. They should not therefore be relied upon in relation to suitability for a particular application. Guidance and advice should always be sought from your JCB Dealer. JCB reserves the right to change specifications without notice. Illustrations and specifications shown may include optional equipment and accessories. All images are correct at time of print. The JCB logo is a registered trademark of J.C. Bamford Excavators Ltd.



9999/5858 09/14 Issue 1 (T3)

